

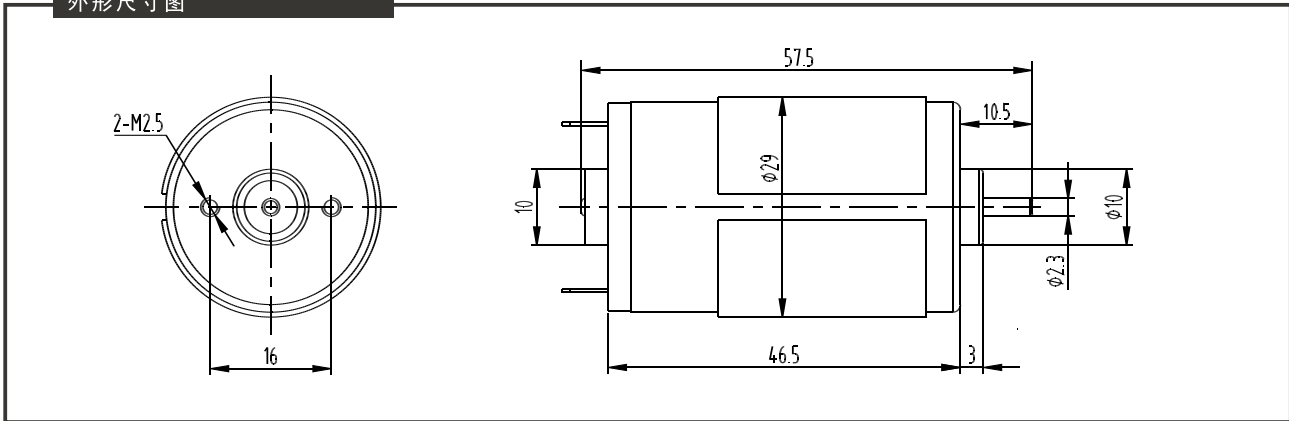

RS-395 DC MOTOR Series

外形尺寸图



马达参数

马达型号	额定电压 V	空载		最大效率下				堵转	
		Current mA	Speed r/min	Current mA	Speed r/min	Torque g·cm	Power W	Torque g·cm	Current mA
RS-395123000	12	< 60	3000	< 250	2200	65	1.4	260	800
RS-395124500	12	< 90	4500	< 430	3300	80	2.6	320	1400
RS-395126000	12	< 130	6000	< 750	4500	105	4.7	420	2600
RS-395243000	24	< 40	3000	< 120	2200	65	1.4	260	400
RS-395244500	24	< 50	4500	< 220	3300	80	2.6	320	700
RS-395246000	24	< 70	6000	< 380	4500	105	4.7	420	1400

RS-395123000 CHARACTERISTICS

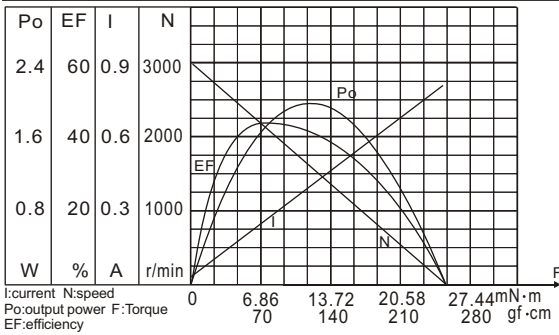

RS-395243000 CHARACTERISTICS

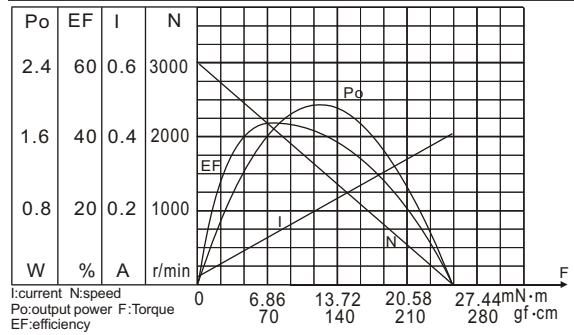

RS-395124500 CHARACTERISTICS

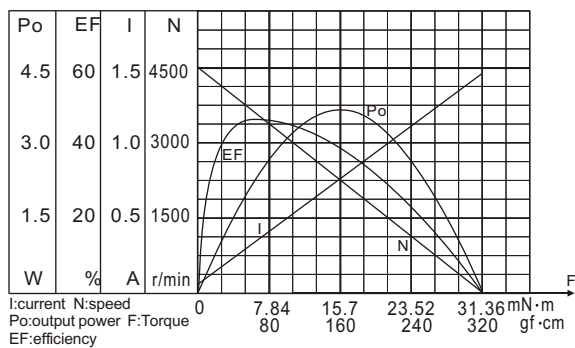

RS-395244500 CHARACTERISTICS

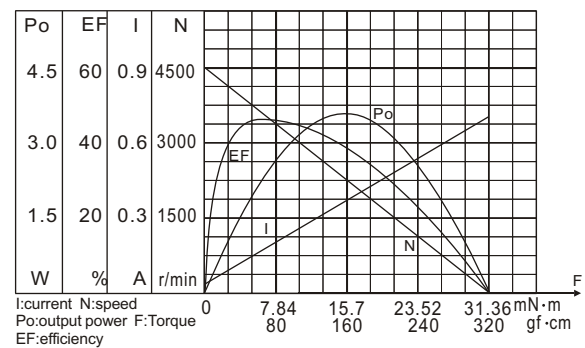

RS-395126000 CHARACTERISTICS

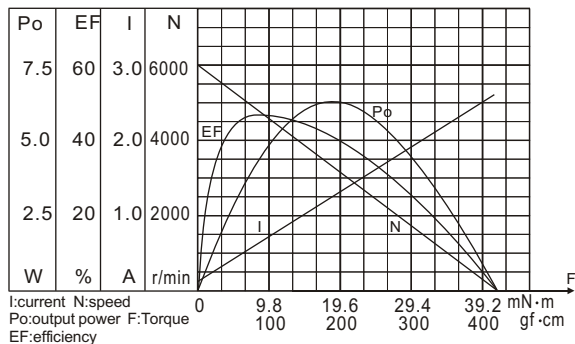

RS-395246000 CHARACTERISTICS

