



# STEPPER MOTOR DRIVER

## SEA2M24

### Features

- High performance, low noise, high speed and torque, excellent stability
- Single / dual pulse input
- 16 selections of uniform angle and constant torque subdivisions, the max resolution up to 40000 steps/rev
- Adoption of 4-wires-control circuit greatly reduces noise and increases the rotation stability
- The max response frequency up to 200KHz
- Once the pulse stops for more than 100ms, the coil current will be halved automatically, to prevent the overheating
- Bipolar constant current chopper control improves the output speed and power of the motor
- Photoelectric-isolated signal input / output
- Current range: 0.1A ~ 2.2A
- Single power input, voltage range: DC24 ~ 50V ( The optimal voltage is DC36V )
- Signal source voltage: DC3.3 ~ 28V ( Arbitrary input without additional current limiting resistor )
- Working mode: Pulse mode, I/O mode
- Error protection: ①Low supply voltage ②High supply voltage ③Phase open Circuit ④Phase overheating
- Size: 92.5×56×21 ( mm ) , Net weight: 0.11kg



### Description

The SEA2M24 is equipped with a 32-bit ARM Cortex-M4 core high-performance microcontroller, which can effectively improve the overall efficiency of the operation speed up to 200MHz in coordination with the advanced process. The drive voltage is DC24V ~ 50V ( The optimal input voltage is DC36V ). It uses a single power supply to supply power. It is suitable for various types of 2-phase hybrid stepping motors with an external diameter of less than 42mm, a phase current of less than 2.2A, and outgoing lines 4 and 8. Double pole constant current chopping mode is adopted inside the driver to reduce the noise of the stepping motor and make the operation more stable; The drive ability and high-speed performance of the stepping motor are greatly improved with the increase of the power supply voltage of the driver; When the step pulse stops for more than 100ms, the coil current automatically reduces by half, reducing the heating of the driver by 50%, and also reducing the heating of the stepping motor. When the pulse frequency is not high, the user can use low speed high subdivision up to 40000 steps/revolution to improve the operation accuracy of the stepping motor, reduce vibration and noise.

### Application

Woodworking engraving machine, laser engraving machine, marking machine, labeling machine, die bonding machine, wire bonding machine, UV printer, 3D printer, inkjet printer, plotter, embroidery machine, glue dispenser, glue filling machine, soldering machine, BGA rework station, laminating machine, placement machine, heat press machine, backlight laminating machine, coating machine, reciprocating machine, terminal machine, wire stripping machine, wire winding machine, solder paste printing machine, PCB drilling machine, V -CUT machine, target machine, FPC reinforcement machine, coating machine, lamination machine, IC sorting machine, IC burning machine, tape machine, medical equipment, non-standard equipment XYZ measuring instrument, connector assembly machine, SMT peripheral equipment, etc.

### Running current setting

Im (A)	0.2	0.3	0.4	0.5	0.6	0.8	0.9	1.0	1.1	1.2	1.3	1.4	1.6	1.8	2.0	2.2
D1	OFF	ON	OFF	OFF	OFF	ON	OFF	ON	OFF	ON	OFF	ON	OFF	ON	ON	ON
D2	OFF	OFF	ON	OFF	OFF	ON	OFF	ON	ON	OFF	ON	OFF	ON	OFF	ON	ON
D3	OFF	OFF	OFF	ON	OFF	OFF	ON	ON	ON	ON	OFF	OFF	ON	ON	OFF	ON
D4	OFF	OFF	OFF	OFF	ON	OFF	ON	OFF	ON	OFF	ON	ON	OFF	ON	ON	ON

### Microstep setting list

Pulse / Rev	200	400	800	1000	1600	2000	3200	4000	5000	6400	8000	10000	12800	20000	25600	40000
D5	ON	OFF	ON	ON	ON	OFF	ON	OFF	ON	OFF	ON	OFF	ON	OFF	OFF	OFF
D6	ON	ON	OFF	ON	ON	OFF	ON	OFF	OFF	ON	OFF	ON	OFF	ON	OFF	OFF
D7	ON	ON	ON	OFF	ON	ON	OFF	OFF	OFF	OFF	ON	ON	OFF	OFF	ON	OFF
D8	ON	ON	ON	ON	OFF	ON	OFF	ON	OFF	ON	OFF	OFF	ON	OFF	OFF	OFF

# SEA2M24

## Dimensions

Side installation drawing

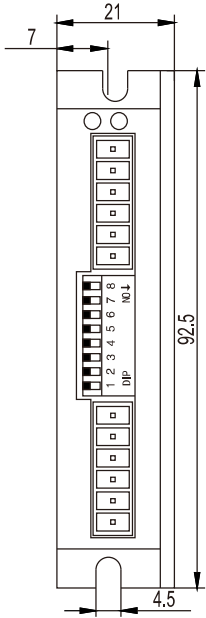

Front installation drawing

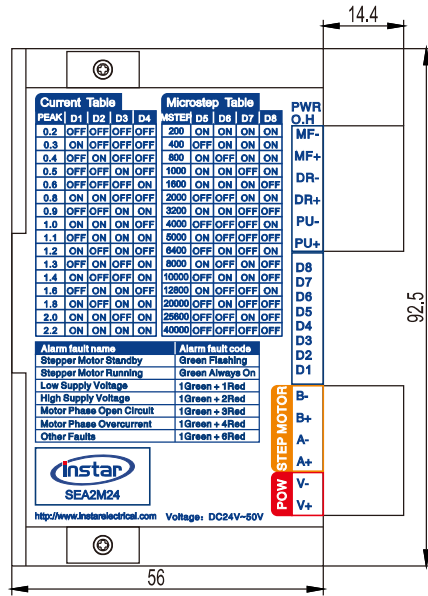

## Wiring diagram

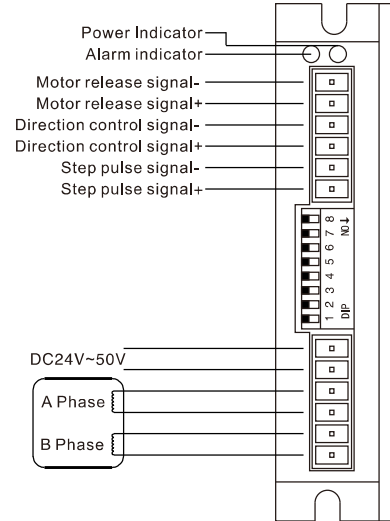

## Pin Function Description

Mark	Function	Instruction
POWER	Power indicator	When the power is on, the indicator light flashes; When receiving pulse signal, the indicator light is always on.
O.H	Fault indicator	The red indicator lamp flashes when the power supply voltage of the stepping driver is low, the power supply voltage is high, the phase is open, the phase is overcurrent, and the encoder is in fault.
MF-	Motor free signal	When the low electrical level is valid, it cuts off the stepper motor current, the driver stops working and stepper motor will be in a free state.
MF+	Input signal positive side	Connects +3.3V~+28V pulse signal power.
DR-	Direction control signal	For changing the direction, input resistance is 220 Ω. Requires: low level +0V~+0.5V, high level +4V~+5V, pulse width >2.5 μs
DR+	Input signal positive side	Connects +3.3V~+28V pulse signal power.
PU-	Pulse signal	When the falling edge is valid, the stepper motor moves a step as the pulse become lower, input resistance is 220Ω. Requires: low level +0V~+0.5V, high level +4V~+5V, pulse width >2.5 μs.
PU+	Input signal positive side	Connects +3.3V~+28V pulse signal power.
-B, +B	Connect to the stepper motor	Please refer to the stepper motor connections.
-A, +A		
+V	Power+	DC24~50V ( The optimal voltage is DC36V )
-V	Power-	